

FAMILY LIFE CYCLE THEORY

This educational CAPPE module ¹ is part ii in section IV:
Theories of Human Development

Written by Peter L. VanKatwyk, Ph.D.

A Family Story

Mrs. Berg came to see her pastor in a state of depression. She located the onset of her distress in her daughter's recent departure from home to stay with a favorite aunt and her family some 500 kilometers away. The move was intended as a time-out strategy in countering a run-away escalation of family stress at home. Mrs. Berg had been the main impetus in getting her 16-year-old daughter out of the house – something that now flooded her with feelings of guilt and regret.

The mother-daughter relationship had been severely conflicted for at least the last two years. A recurring memory of an especially ugly fight on the eve of her daughter's departure, had become an obsession in the mother's mind. In sharp contrast, her husband could look back on a largely pleasant, often playful, relationship with his daughter. The mother was left isolated and resentful in losing a daughter from whom she felt now separated not only relationally but also geographically. She was grieving a double loss, both stemming from her sense of failure as a parent.

Questions:

- What ways can you think of in which a spiritual care-provider could conceptualize this crisis situation?
- What possible helping-strategies come to mind?
- Whom would you prefer to work with:
 - individually with Mrs. Berg, Mr. Berg, or the daughter?
 - systemically with the family or the couple?

The Time Perspective.

Families are shaped by people who share a history and a future together. From this time perspective families are living systems moving through time. With the contemporary family pulsing with plural, multicultural patterns there is not one set course or normative sequence by which families develop over time. Monica McGoldrick and Betty Carter in their respected work on the family life cycle describe its underlying processes to be negotiated by “the expansion, contraction, and realignment of the relationship system to support the entry, exit, and development of family members in a functional way” (2003, 384). Major life-cycle transitions are marked by fundamental changes in the family system itself (second order changes) rather than rearrangements within the system (first order changes). McGoldrick and Carter have designed a classification of critical, fundamental family life-cycle stages of American middle-class families in the beginning of the 21st century (1999, 2).

Their classification table lists six stages of the family life cycle:

1. Leaving home: single young adults
2. The joining of families through marriage: the new couple
3. Families with young children
4. Families with adolescents
5. Launching children and moving on
6. Families in later life

Each of these life cycle stages is correlated with two major dimensions:

1. Emotional Process of Transition: Key Principles.
2. Second-Order Changes in Family Status Required to Proceed Developmentally.

Case Illustration #1

According to the above chart the Berg family is in stage 4. The adolescent daughter triggers the life cycle transition that throws the family system out of balance. Following the chart, stage 4 describes the emotional process of transition as follows:

“Increasing flexibility of family boundaries to permit children’s independence and grandparents’ frailties.”

This stage involves the following second-order changes in family status:

- *Shifting of parent/child relationships to permit adolescents to move into and out of system*
- *Refocus on midlife marital and career issues*
- *Beginning shift toward caring for older generation.*

Questions

from a family life cycle perspective on the Berg family:

- what do you see as primarily responsible for causing the problem?
- who is best positioned for addressing and solving the problem?
- where to start – with the problem or with the solution?

The time perspective relates problems to the flow of stress through the family and how it is addressed in the process of family coping. Therapists have long noted that presenting problems often coincide with critical transition points in the family life cycle (Haley, 1973). Problems can take on a life of their own, reified as distinct entities, rather than being the signals that punctuate critical moments in the life cycle. For families and couples such awareness helps in normalizing their crisis experience of what may appear catastrophic. Carter and McGoldrick observe: “Families characteristically lack time perspective when they are having problems. They tend generally to magnify the present moment, overwhelmed and immobilized by their immediate feelings; or they become fixed on a moment in the future that they dread or long for. They lose the awareness that life means continual motion from the past into the future with a continual transformation of familial relationships” (1999, 4).

Life cycle transitions shift the state of family relationships and require a repositioning in the relational dynamics. This is the “emotional process” (Kerr & Bowen, 1988) by which the family regulates the balance between individuality and togetherness, the dance between contraction and expansion in the evolution of family relationships.

The Genogram as Assessment Instrument

The *genogram* is a popular and useful instrument as a graphic representation of the family as an emotional system moving through space and time over at least three generations (McGoldrick & Gerson, 1985; Carter & McGoldrick, 1999). The genogram maps recurring behavioral patterns and emotional ties between family members. The genogram has become a standard assessment tool for a systemic approach in therapy and is generally shared with the family. Presenting problems lose their narrow focus on the individual when they begin to tell the story of the family. The genogram differentiates between the various roles by which each person participates in the family system. Edwin Friedman in *Generation to Generation* (1985, 32-34) shows examples of how multigenerational transmission can be charted on genograms to help family members gain more distance from their immediate lives and concerns.

Case Illustration #2

According to the genogram in Figure 1, Mrs. Berg is the oldest of five children in her family of origin. Not only being the first born, but also the untimely death of the second child, distanced Mrs. Berg from her younger siblings and accentuated her care-taking role as the parental child in the family. She was close to her mother, the primary parent in spite of some 30 hours per week she worked outside the home as a cleaning lady. The father was a quiet, unobtrusive man, the night clerk in the local hotel, and largely peripheral to the day-to-day events in his own family. Her next younger sister is the only sibling that attended university. She has established a life style of her own, often at variance from the more conventional values in the family of origin, presently living in a committed lesbian relationship with the child from her partner's previous relationship. Her youngest sister had a car accident in her early teens, which has left her with some mental impairment. She lives at home with her mother. Her brother has moved from the East to the West Coast from where he maintains pleasant but sporadic contacts with the family.

Mrs. Berg has a long and ongoing history of being close to her mother. In the family of origin the mother depended on Mrs. Berg as a co-parent, especially at the times when she was working outside the home. Mrs. Berg still receives frequent calls from her anxiety-prone mother, often related to her youngest sister who at the age of 34 continues to require ongoing emotional and practical support. In exploring the relationship with her mother, Mrs. Berg became aware how limited her experience had been of being a “daughter” or a “child.” With her mother coping with long hours and functioning virtually as a “single” parent, Mrs. Berg was prematurely recruited as co-parent in a large family.

Mrs. Berg's family of origin is connected with Mr. Berg's family of origin in their shared genogram (Figure 1). In his family of origin, Mr. Berg is the youngest child with two older sisters. His father, after a long and lingering illness, died when he was 5 years old. His oldest sister, apparently feeling displaced by her more glamorous and popular younger sister, the star of the family, early on distanced herself from the family, culminating in her immigration to Australia. Mr. Berg grew up as a carefree child, much doted on as the baby of the family by both his mother and his next older sister. Not surprising, he married another "older sister," and continued a congenial and pleasant existence, working part-time as a music teacher in the town's high school, while owning a rental store specializing in musical instruments and gardening and building equipment.

Couple relationships generally work in a complementary fashion. In the Berg couple economy, Mrs. Berg does most of the worrying: she takes responsibility as primary parent and homemaker and as the bookkeeper of the store. Mr. Berg does most of the pleasing and contributes to a comfortable atmosphere in the home and in their social relationships. The couple describes their relationship as a balancing act between Mrs. Berg being "the pessimist" and Mr. Berg "the optimist." In this arrangement it makes sense that in addressing their family crisis Mrs. Berg is assigned the task of being the identified patient with the presenting problem of "depression."

Figure 1: The Berg Genogram

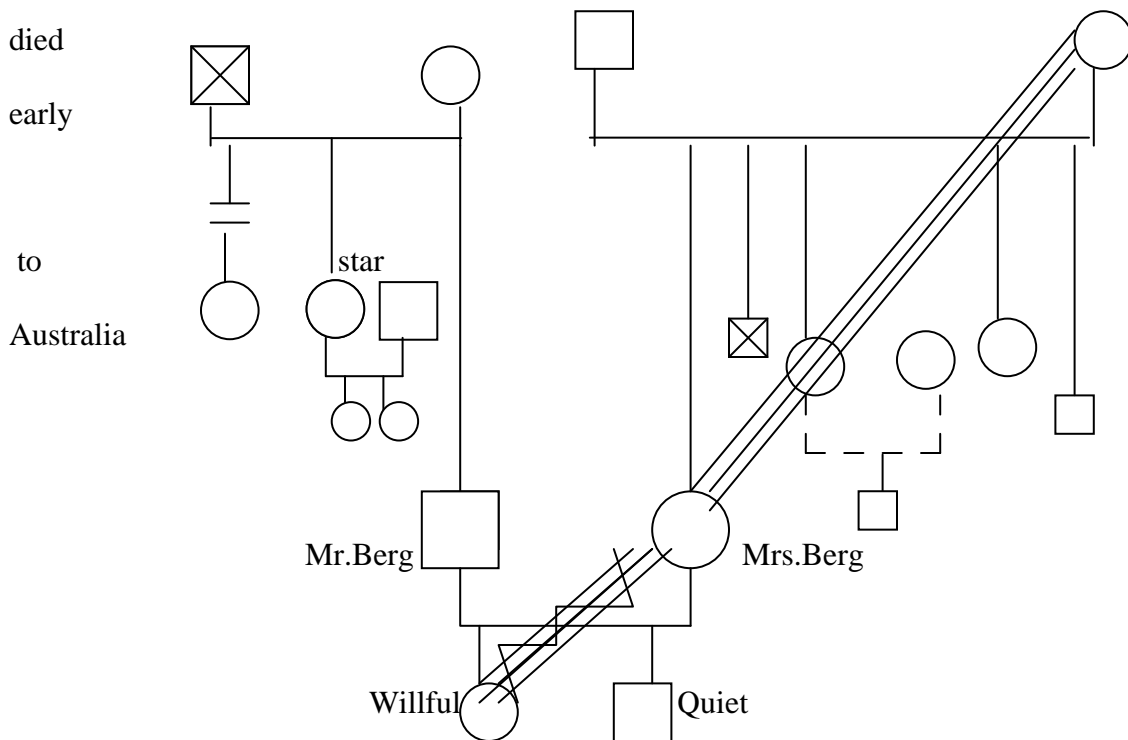

Symbols used:ⁱⁱ

Very close relationship

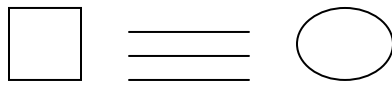

Male

Female

Estrangement or cut off

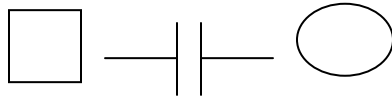

Conflicted relationship



Family Development through Stress and Crisis

The time perspective links problems to the family process of coping with life stressors. The extensive literature on family stress emphasizes that stress is an inherent part of family life. Some stressors are predictable and normative, such as life cycle transitions, while others are unpredictable, catastrophic events, including untimely death, accidents, unemployment, natural disasters, and war. With the ubiquity of stress, successful families major in engaging rather than avoiding the stresses in their lives. In his classic research study of postwar families in the 1940's, Reuben Hill (1949) identified two crucial factors in the family process of coping with stress:

- 1) the family resources in coping with the stress
- 2) the family's definitions in interpreting the stress

Subsequent family stress theory has refined Hill's original conceptual model, but the twofold formula of coping with stress through the process of interacting resources and interpretations has remained a helpful paradigm (Figley & McCubbin, 1983; Burr & Klein, 1994; Mullen & Hill, 1990). From this perspective, family stress arises from an actual or perceived imbalance between the demands of life and the family's capability in meeting these demands and transforming them into positive outcomes.

In the above definition, the critical criterion for the impact of stress lies in how it is met. Stress becomes distress when experienced as catastrophic. In contrast, stress becomes "eustress," or growth producing, when actively engaged as a challenge. When stress cannot be successfully addressed with the available or customary coping style, stress becomes crisis. Family crisis occurs in circumstances that require the family to change

its basic structure of being and doing things in response to stress. This crisis definition clarifies that stress may never reach crisis proportions if the family is able to meet the stress situation without having to change its basic family structure.

A Theological Reflection

- does a religious or spiritual “conversion” require a crisis?
- does “conversion” apply to a systems context, like a couple, family, community?

The *double ABCX model of family stress model* (McCubbin and Patterson, 1983) presents a framework of viewing family adaptations to multiple stressors over time through the use of family resources and perceptual factors in coping. Potential crisis depends on the interaction of the *stressor* with existing *resources* and with family *perception*:

- Resources are the psychological, social, interpersonal, and economical characteristics of individual family members in interaction with the family and the community. In a time frame, there are two types of resources: those already present and those cultivated in responding to new demands emerging out of the *pile-up* of stressors, old and new.
- Here are also two kinds of perception that can be distinguished. The first is the initial definition of the stressor by the family on a continuum from hopeless to challenging. The second form of perception refers to how the family over time redefines the stressor in the context of new experiences and the total situation.
- The thrust of the ABCX model is a systemic interaction of multiple factors over time directed towards adaptation - a new balance of the family system.

The Double ABCX Model ⁱⁱⁱ

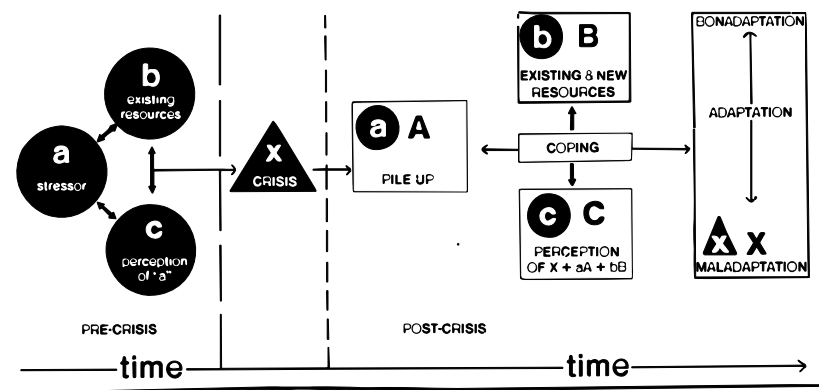

Case Illustration #3

The definition of family stress is demonstrated by the Berg family in their utilization of:

- *family resources*
 - *The integrity of the marital system. Rather than a divisive triangle formation with a benevolent father aligning with the daughter against a demanding wife/mother, the couple maintains mutual loyalty and addresses the need for change first in their own relational system.*
 - *An active extended family. There is a safety net of outside family relations providing temporary respite to both daughter and mother.*
 - *Their openness in mobilizing extra-familial counsel and support by reaching out to their pastor.*
 - *Financial resources generated by the couple, evident in re-settling the daughter.*

- *family interpretation*
 - *Initially the problem was defined in individual terms and through pathology labels: the daughter being targeted as the problem and the mother as the victim/patient in need of treatment. Psycho-educational family theory input from the pastor helped to normalize the family stress situation while validating the integrity of the marital relationship.*
 - *A role differentiation approach through the genogram provided a wider system vision and flexibility by de-focusing the dominance of the mother role.*

Meaning-Making Family Process

Constructivist theory holds that human beings are irrepressible meaning-making creatures who construct out of their lived experience the realities they live by. Constructivist/narrative care invites people to dialogue and share personal stories to jointly assess, deconstruct and reconstruct old meanings and create new meanings (Rosen & Kuehlwein, 1996). Adapting a Carter & McGoldrick (1999, 6) diagram, figure 2 depicts the horizontal time dimension of the flow of stress through the family intersecting with a vertical dimension of prior experiences and meanings that inform the process of interpreting the stressors. Meaning-making constructs exist on many levels - individual, marital, familial, social, religious and cultural – that conjointly determine the meaning attributed to presenting stress events.

Historical consciousness expresses itself in a tradition, i.e. in a set of memories which are delivered from one generation to the other, Tradition is not a casual collection of remembered events but the recollection of those events which have gained significance for the bearers and receivers of the tradition. The significance which an occurrence has for a tradition-conscious group determines whether it will be considered a historical event. Paul Tillich, 1967, 300.

The family as a meaning-making culture constructs a family reality – a reality that is maintained in family stories, myths and legacies, and through emotional and relational patterns in triangles, alliances, rules, and expectations. Families are embedded in larger sociocultural meaning-making cultures articulated in beliefs, attitudes and prejudices on such life issues as power, sexuality, gender, race and ethnicity, success and failure, and religious values.

Case Illustration #4

The Berg couple shows a tradition of strong women in correlation with decent but rather passive men. The stress impact of this tradition of women responsible for managing their families likely increased the level of anxiety in the family 's emotional system when Mrs. Berg increasingly felt unable to live up to this legacy. In contrast, this same tradition can interpret the daughter's wilfulness as a sign of strength of character: she is able to stand up to her mother, something that her own mother had trouble doing with her mother.

An example of horizontal stress intersecting with vertical stress-inducing history in the Berg family relates to emotional cutoffs of daughters and their families. Emotional cutoff is a Bowen concept that describes the way family members manage the emotional intensity and lack of differentiation between them and between the generations (Kerr & Bowen, 1988, 271ff). In Mr. Berg's family of origin this happened with the oldest daughter who both geographically and psychologically left for another continent. This cutoff has been compensated for by the younger daughter who maintains a double presence in the family, who also at this point in time substitutes by providing a home away from home for the Berg daughter. In Mrs. Berg's family of origin a complicating piece of family history that may contribute to the present crisis, is the experience of a lost child in the untimely death of her brother.

Figure 2: The Coping Process

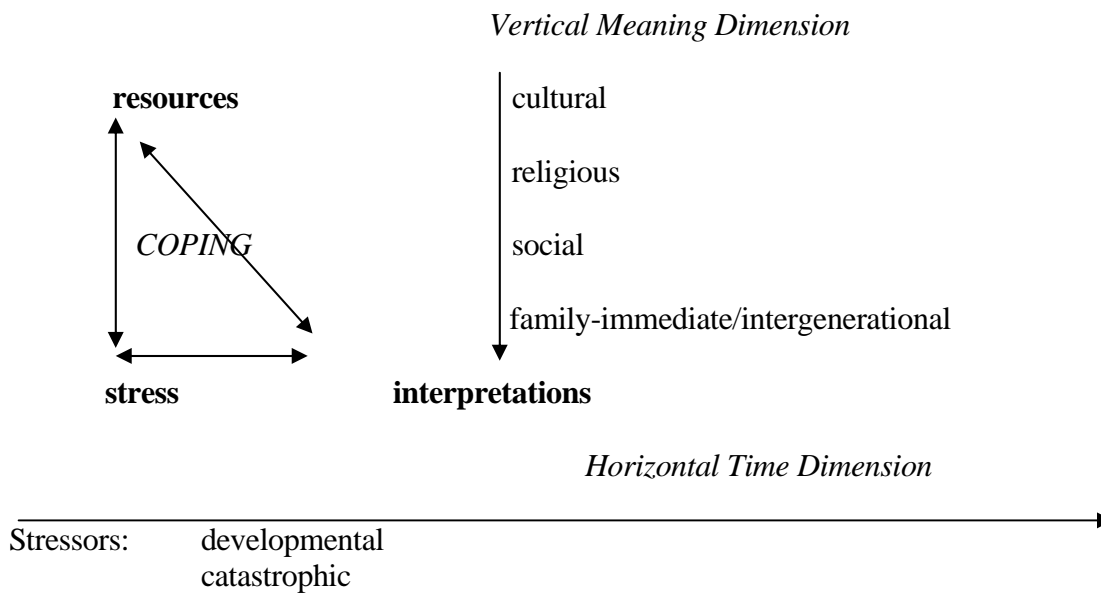

Dimensions of Transformation

The process of interpretation is crucial in the practice of spiritual care and counselling. This hermeneutical approach provokes new meanings and constructs alternative personal and family realities. These shifts in perspective translate into basic life changes. Family theory distinguishes three levels of change:

1. Level I change is defined as change within the family system, without effecting its basic structure (Watzlawick, Weakland, & Fisch, 1974)
2. Level II change, better known as “second-order” change, impacts the structure of the system itself (Watzlawick, Weakland, & Fisch, 1974). The goal of level II change is not to change something in the system but to change the system itself.

Case Illustration #5

In the Berg family, a level I change is negotiated when the daughter leaves to live with her aunt and family. This change maintains the structural parts of the family, and the larger extended family such as the substitutionary role of the aunt. Even though it is likely a helpful change, providing a pause in escalating conflict, it does not change the basic organization in the family system. In contrast, when counselling the Berg couple would address fundamental patterns of their interaction, such as the polarity between Mr. Berg’s under-responsible and Mrs. Berg over-responsible stand, a positive outcome would be a second-order change.

3. Level III change is the most radical change as it effects basic life orientations (Reiss, 1981). Beyond the family system it refers to one’s place in the world. Level III change is a shift in paradigms, in the basic beliefs and assumptions about life. There are many stories of radical change in human life, transformations that are researched and identified as instances of “quantum change” (Miller & C’de Baca, 2001). At moments of severe stress a person, couple or family may go through a transforming experience similar to a life-changing spiritual conversion.^{iv}

Case Illustration #6

The closest example in the case study is the personal life re-orientation in Mrs. Berg. She begins to question the meaning of responsibility and caretaking - core values that have organized her life, robbed her from her childhood, and let her down in a crisis of mounting family stress. Repositioning herself in the family as a whole person, not confined to the parent role, calls for a systems conversion where the marriage redefines itself. Such a change in the context of couple therapy will trigger a parallel process in Mr. Berg as he critically assesses his own placating strategy (Satir, 1988, 85) in adapting to the stress of life and the family.

Conclusion

Change theory clarifies that family life cycle transitions are generally second-order, at rare and special times, third-order changes. Radical change involves both role differentiation and time perspective. Role differentiation is a re-orientation in *space*: how persons situate themselves in the structure of their intimate relationships and in their world. Life cycle perspectives facilitate a re-orientation in *time*: how persons envision their lives flowing from the past into the future, inviting continual transformation by reframing problems into challenges.

Third-order change is an ambitious goal: seeking to integrate time and space dimensions in the creation of new structures of meaning. As Anderson & Worthen (1997, 3) describe this process in an article on spirituality as a resource in couple therapy: “Three dimensions of experience addressed by most therapies are time (events occurring in sequences), space (experience organized through the structure of relationships), and story (the use of language to shape what has occurred in time and space into structures of meaning). The latter includes stories told inside our heads, stories told to others with whom we interact in time and space, stories that families construct and pass on over generations, and stories constructed by societies and cultures.”

A spiritual approach follows the personal and communal stories and the faith people live by and share with intimate others. Spiritual care has a special entrée and vocation in attending to these stories by co-interpreting and, at times, co-scripting alternative versions of life and the performance of the rituals of transition.

REFERENCES

- Anderson, D., & Worthen, D. 1997, "Exploring a Fourth Dimension: Spirituality as a Resource for the Couple Therapist," *Journal of Marital and Family Therapy*, 23 (1): 3-12.
- Burr, W., Klein, S., & Associates. 1994. *Reexamining Family Stress: New Theory and Research*. Sage.
- Figley, C. & McCubbin. 1983. *Stress and the Family, Vol. II, Coping with Catastrophe*. Brunner/Mazel.
- Friedman, E. 1985. *Generation to Generation: Family Process in Church and Synagogue*. Guilford.
- Haley, J. 1973. *Uncommon Therapy*. Norton.
- Hill, R. 1949. *Families under Stress: Adjustment to the Crisis of War, Separation and Reunion*. Harper.
- Kerr, M., Boqwen, M. 1988. *Family Evaluation*. Norton.
- McCubbin, H., Figley, C. 1983. *Stress and the Family, Vol. I Coping with Normative Transitions*. Brunner/Mazel.
- McGoldrick, M. & Gerson, R. 1985. *Genograms in Family Assessment*. Norton.
- McGoldrick, M., Carter, B. (Eds.). 1999. *The Expanded Family Life Cycle: Individual, Family, and Social Perspectives*. Allyn & Bacon.
- McGoldrick, M., Carter, B. 2003. "The Family Life Cycle," in Walsh F., *Normal Family Processes*. Guilford.
- Miller, W., & C'de Baca, J. 2001. *Quantum Change: When Epiphanies and Sudden Insights Transform Ordinary Lives*. Guilford.
- Mullen, P. & Hill, E. "A Family Systems Model for Pastoral Care and Counseling in Times of Crisis," *The Journal of Pastoral Care*. Fall 1990, Vol. XLIV, No. 3.
- Reiss, D. 1981. *The Family's Construction of Reality*. Harvard University Press.
- Rosen, H., & Kuehlwein, K. (Eds.). 1996. *Constructing Realities: Meaning-Making Perspectives for Psychotherapists*. Jossey-Bass.
- Satir, V. 1988. *The New People Making*. Science and Behavior Books.
- Tillich, P. 1967. *Systematic Theology – Three volumes in one*. University of Chicago.
- Watzlawick, P., Weakland, J., & Fisch, R. 1974. *Change: Principles of Problem Formation and Problem Resolution*. Norton.

NOTES

ⁱ This module is an adaptation of the chapter "Textures and Threads: Life Cycle Transitions" in Peter L. VanKatwyk, *Spiritual Care and Therapy*. 2003, 95-104.

ⁱⁱ For a complete list of symbols see McGoldrick & Gerson. 1985. *Genograms in Family Assessment*.

ⁱⁱⁱ The source for this figure is Hamilton & McCubbin, "Chronic Illness: Family Stress and Coping," in Figley, C. & McCubbin, H., *Stress and the Family, Vol. II, Coping with Catastrophe*. 1983, 27.

^{iv} See module III, iv, *Varieties of Spiritual Experience*.